

Our Experience Is The Shaping Of The Uppers

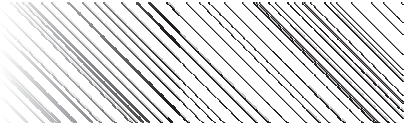

Multiform 3

Versatile Back-part Molding Machine With
Two Hot & Two Cold Stations



Versatile Back-part Molding Machine With Two Hot & Two Cold Stations

Multiform 3 distillates 40 years of experience and development into the back-part moulders. It combines all the advantages of the previous POLYFORM generation machines with those of Multiform 99 and creates a very dynamic and economic unit that offers all the quality you could ask. Multiform 3 shapes with the same ease high quality women's, men's and children's uppers as well as boots and mini counters.

Thermoplastic or leatherboard counters

The standard version of this machine is equipped with two hot and two cold stations for thermoplastic counters, but it can be delivered on demand with four hot stations for maximum results on leatherboard counters too.



5 Operations in One Machine

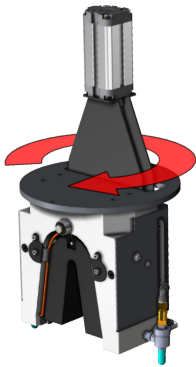

Rotating cushion system with integrated wipers

The Multiform 3 is equipped with the Olympic patented rotating cushion with integrated wipers that ensures a high perimetric pressure and shaping of the upper in combination with excellent upper flanging.

- Can be rotated in seconds.
- Demanding procedures made simple.
- Offers great versatility in production.

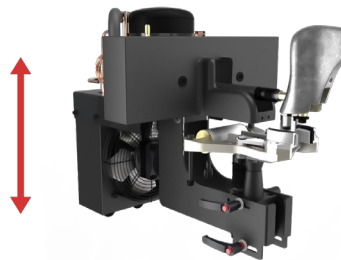

New redesigned moving cooling unit system

The Multiform 3 with its two independent cooling units ensures fast and excellent results for your uppers. With lifetime warranty and no downtimes during production.



New redesigned led projector for accurate upper positioning.

Pincers with inclination

The pincers of the Multiform 3 is a new developed system which can easily take inclination for high heel uppers

- Adapted to last's shape
- Easy angle adjustment
- Quick adjustment

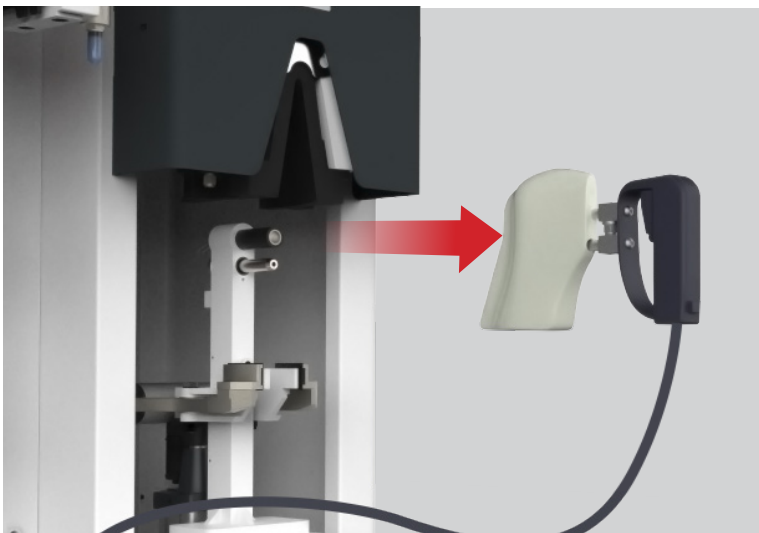
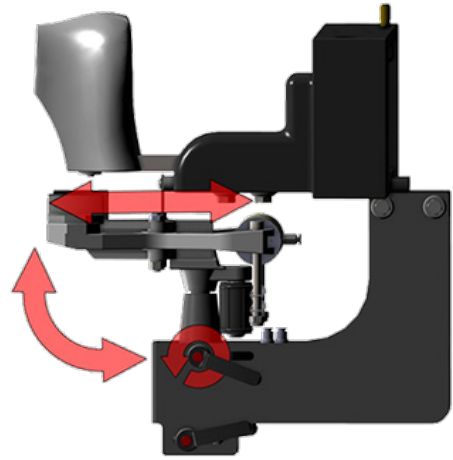

New quick release hot station mould system

- Easy to remove with 2 simple moves
- Avoid downtime, change your production procedure in seconds

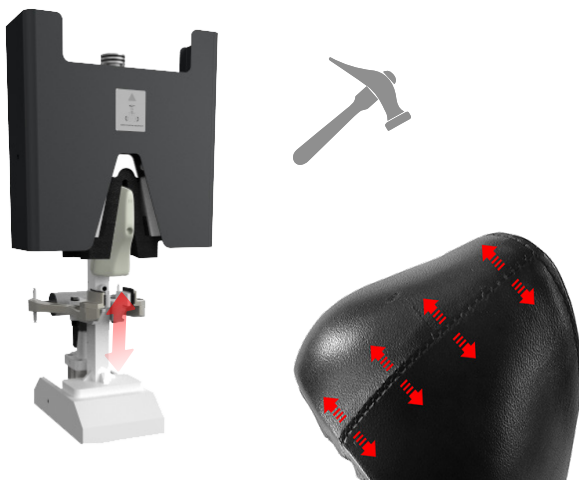

Brand New stitch hammering function

Brand New stitch hammering function helps you to smooth the stitchings, giving you a very nice surface.

Rotating Cushion System With Integrated Wipers

The Multiform 3 is equipped with the Olympic patented rotating cushion with integrated wipers which ensure a high perimetric pressure and shaping of the upper in combination with excellent upper flanging.

The patented cushion can be rotated in seconds allowing demanding procedures made simple and offers great versatility in production

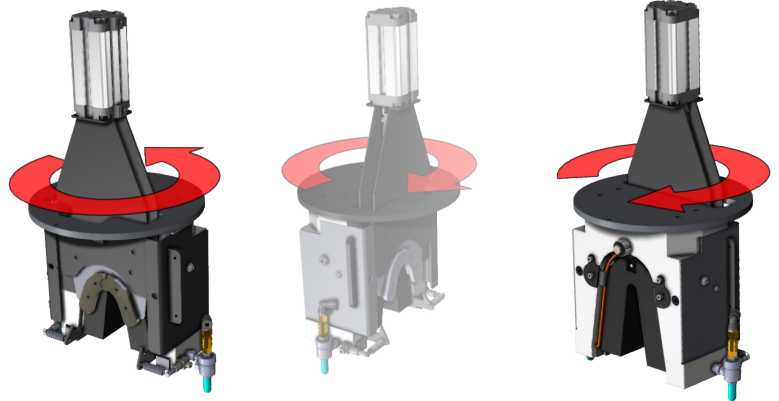

Moccasin moulding

Conversion time 5 Min

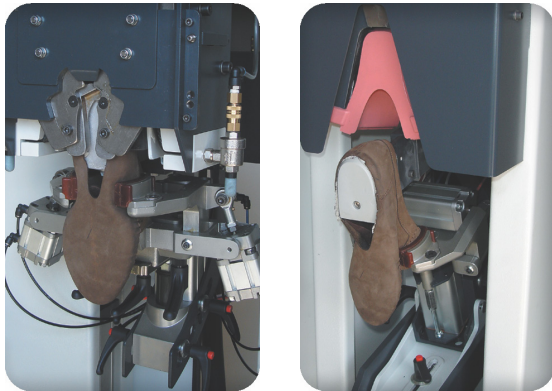

Multiform fits in any production

Conversion time 2 Min



	Cushion with integrated wipers & tubular Male-female moulds Thermoplastic counter flanging
	Inflatable Cushion without wipers Universal moulds Excellent shaping No flanging Suitable for thermoplastic and leatherboard counters

Specifications

Operation	Electro - Pneumatic
Pressure	6 bar
Voltage	230V single phase 50Hz
Capacity	1100 pairs per 8 hours max
Power Consumption	2500 W
Dimensions (mm)	1660 (w) x 855 (d) x 2030 (h)
Weight	580 Kgs