

Our Experience Is The Shaping Of The Uppers

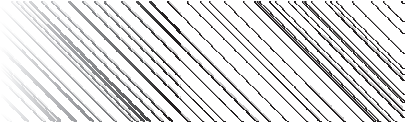

OLYMPIC
Engineering

Multiform 4

Versatile Back-part Molding Machine With
Two Hot & Two Cold Stations

- Individual pincers
- Over-stretching system
- High heel uppers up to 140mm



Versatile back-part moulding machine with two hot & two cold stations

Multiform 4 is a back-part moulding machine dedicated to the production of high quality shoes. Designed and created to be the fundamental and most powerful tool for shoemakers aiming for perfection. Multiform 4 shapes with equal ease high quality women's, men's and children's uppers as well as boots, moccasins and mini counters.

Thermoplastic or leatherboard counters

The standard version of this machine is equipped with two hot and two cold stations for thermoplastic counters, but it can be delivered on demand with four hot stations for maximum results on leatherboard counters too.



5 Operations in One Machine

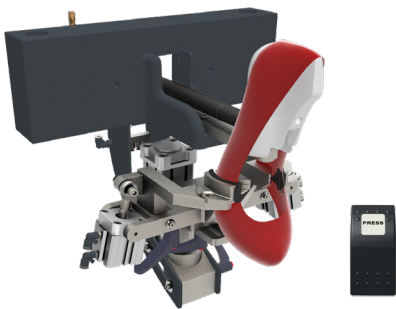

Over-stretching system

Same production uppers often are a little different and require different amount of pulling. Normally, the user pulls the uppers two or more times and this leads to undesired extension.

- Eliminates the above mentioned phenomenon
- Allows the user to add the minimum extra pulling that each upper requires

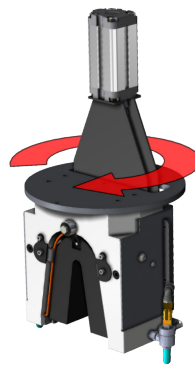

Rotating cushion system with integrated wipers

The Multiform 4 is equipped with the Olympic patented rotating cushion with integrated wipers that ensures a high perimetric pressure and shaping of the upper in combination with excellent upper flanging.

- Can be rotated in seconds.
- Demanding procedures made simple.
- Offers great versatility in production.



New redesigned moving cooling unit system

The Multiform 4 with its two independent cooling units ensures fast and excellent results for your uppers. With lifetime warranty and no downtimes during production.

Back-part moulding

Divided Independent Pincers

The position of each Divided Pincer is adjusted independently according to the perimetrical shape of the aluminum last.

- Adapted to last's shape.
- Easy angle adjustment.
- Quick adjustment



New quick release hot station mould system

- Easy to remove with 2 simple moves.
- Avoid downtime, change your production procedure in second



Hot station pincers

- New generation, hot station design, fully adjustable for flat and high level heel uppers
- Simple adjustments
- Universal lasts and moulds
- Inclination allows user to pull high-heeled shoes without harming the top line (up to 14cm)

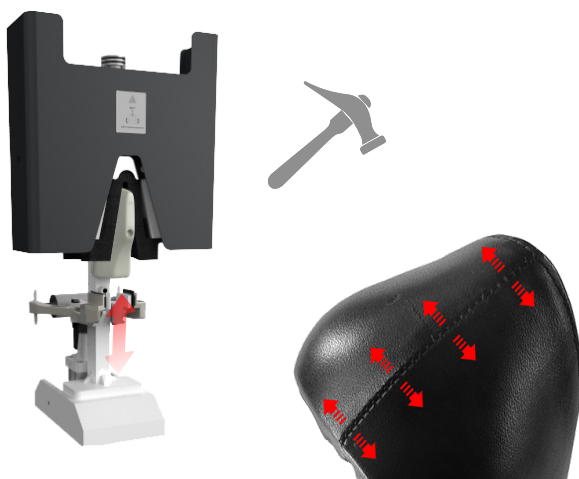

Brand New stitch hammering function

Brand New stitch hammering function helps you to smooth the stitchings, giving you a very nice surface.

Rotating Cushion System With Integrated Wipers

The Multiform 4 is equipped with the Olympic patented rotating cushion with integrated wipers which ensure a high perimetric pressure and shaping of the upper in combination with excellent upper flanging.

The patented cushion can be rotated in seconds allowing demanding procedures made simple and offers great versatility in production.

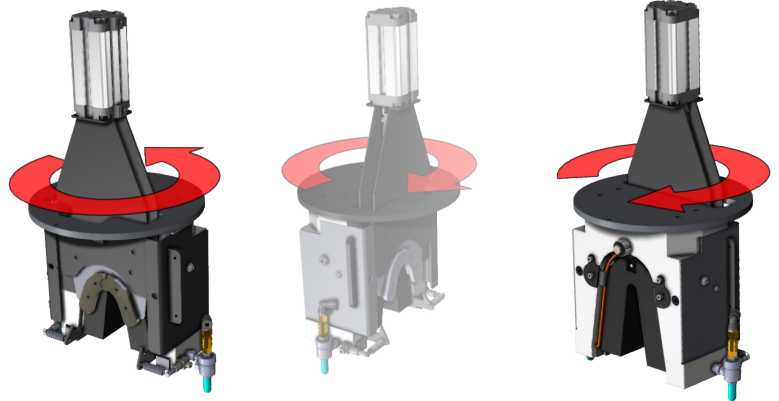

Mini counter moulding

Conversion time 2 Min



Moccasin moulding

Conversion time 5 Min

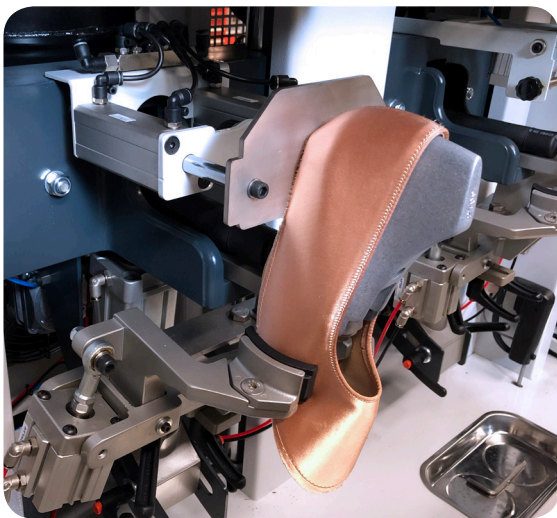
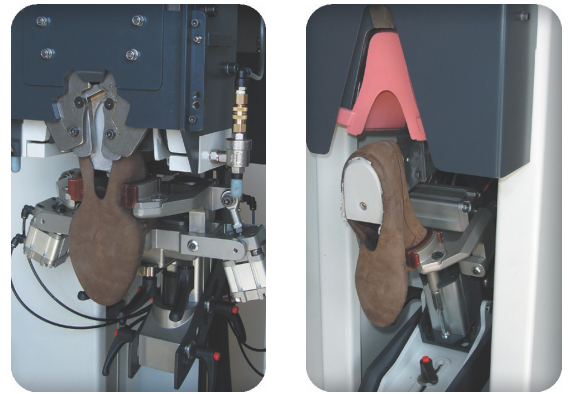

Accurate Upper Positioner (Optional)

For higher efficiency and precision use the accurate upper positioner.

- Increased repetitivity
- Plug & play installation
- Easily adjusted

Specifications

Operation	Electro - Pneumatic
Pressure	6 bar
Voltage	230V single phase 50Hz
Capacity	1100 pairs per 8 hours max
Power Consumption	2500 W
Dimensions (mm)	1660 (w) x 855 (d) x 2030 (h)
Weight	580 Kgs